

6714A2327

copiatore pinza ER25; attacco HSK F63
copier ER25 collet; HSK F63 coupling

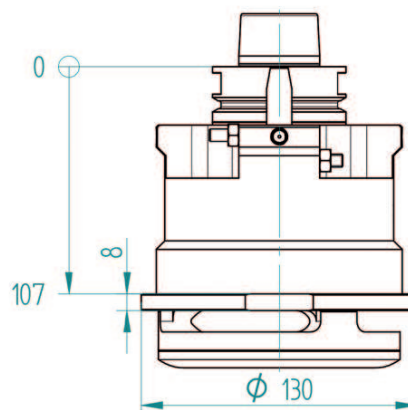
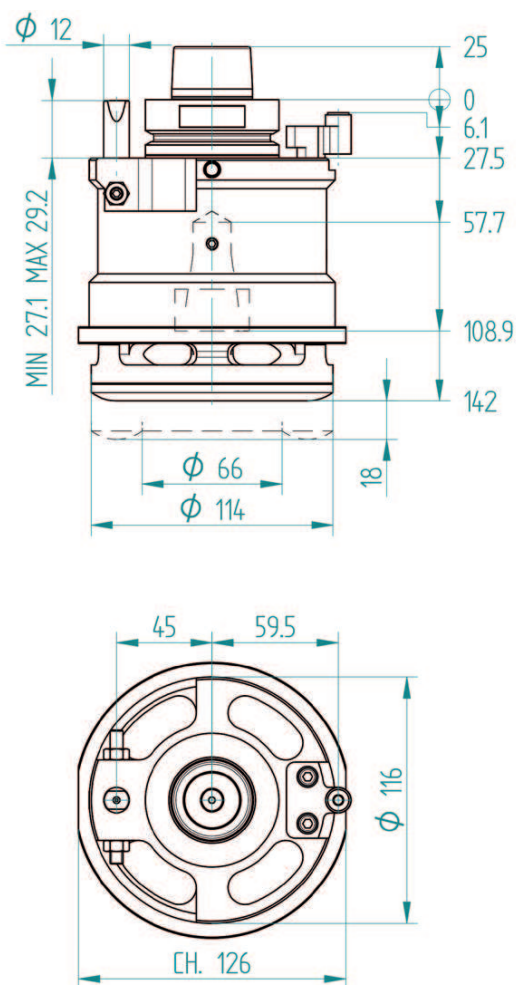

Velocità di rotazione elettromandrino / <i>Electrospindle rotation speed</i>	rpm	18000	valore max / <i>max value</i>
Velocità di rotazione utensile / <i>Tool rotation speed</i>	rpm	18000	valore max / <i>max value</i>
Rapporto di trasmissione / <i>Speed ratio</i>		1 : 1	
Attacco elettromandrino / <i>Electrospindle coupling</i>		HSK F63	
Diametro codolo / <i>Tool shank diameter</i>	mm	1 ÷ 16	
Diametro punta max / <i>Max bit diameter</i>	mm	16	
Diametro lama / <i>Blade diameter</i>	mm	-	
Profondità di lavorazione / <i>Working depth</i>	mm	-	
Peso / <i>Weight</i>	kg	~ 6	
Lubrificazione / <i>Lubrication</i>		-	
Temperatura di esercizio / <i>Working temperature</i>	°C	70	valore max / <i>max value</i>